



PLEASE READ CAREFULLY BEFORE PROCEEDING WITH INSTALLATION

Product Disclaimer

- A vehicle modified by the uses of competition product(s) for use on public roadways may not meet local, state or federal regulations. Installation and use of this competition product(s) may also affect vehicle insurance coverage. It is the purchaser's responsibility to meet and comply with regulations and policies before operating the vehicle on public roadways.
- Return of product(s) will **ONLY** be accepted if product(s) is in resalable condition. All accepted returns will be subject to a 20% restocking fee. **ABSOLUTELY NO RETURNS ON USED PRODUCTS.** For more information on our return policy, please call (951) 808-9888.
- For technical support, visit the Help Desk at www.skunk2.com or call (951) 808-9888
- Group-A Autosports, Inc., recommends the following performance products to maximize power gains:
 - Header/high-flow exhaust systems
 - Cold-air intake system
 - Fuel pressure regulator
 - Camshafts/adjustable cam gears

Warranty Policy

Group-A Autosports, Inc. warrants all products to be free of defects in materials and workmanship for normal use and service for a period of 1 year from the date of retail purchase. Products returned must be inspected and determined to be defective by Group-A Autosports Inc., before any warranty credit and/or replacement is issued. Group-A Autosports, Inc.'s obligation under warranty shall be limited to repairing or replacing, at its discretion, any product found to be defective. The consumer will be responsible for transportation charges. Final determination of the special, direct, indirect incidental or consequential damages that may be claimed as a result of the failure of any product, including claims for delay, loss of profits or labor. Group-A Autosports Inc., shall not be liable for any damage and/or injury to person(s) and/or property resulting from improper installation and/or misuse of any product subject to this warranty. There are no other warranties expressed and/or implied extending beyond those set forth above.

PART#: 309-10-0200

Miata NB Throttle Body

This throttle body fits the following applications:

1999-2005 Mazda Miata

Included items with Skunk2 Throttle Body – Please inspect each item for defects before installation

- | | |
|---------------------------------|---------------------|
| (1) Skunk2 Throttle Body | (4) M8x1.25x25 Bolt |
| (1) Idle Control Mount Spacer | (1) M6x1.0x12 Screw |
| (1) Throttle Body Gasket | (1) M6x1.0x22 Screw |
| (1) Idle Control Gasket, Top | |
| (1) Idle Control Gasket, Bottom | |
-

Removal Instructions:

1. Disconnect the negative battery terminal.
2. Remove the intake tube and throttle cable.
3. Remove the OEM throttle body from the intake manifold.
4. Measure the resistance in the factory TPS by connecting an ohmmeter to terminals A and B as shown in Figure1. Record this value as it will be used in installation.
5. Remove the factory IACV and TPS from the throttle body unit.

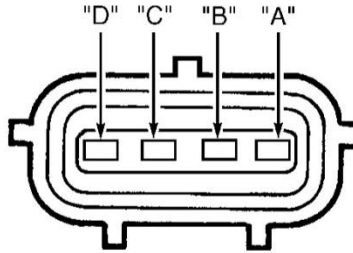
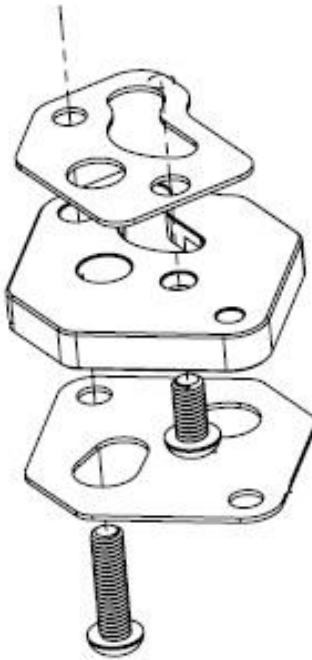

Figure 1

Installation Instructions:

1. Install the IACV spacer with the included gaskets using the two supplied M6 screws. Reinstall the factory IACV.
2. Install the factory TPS. Calibrate the TPS by rotating the sensor and measuring the resistance between terminals A and B as shown in Figure 1. Once the setting is the same as was recorded during removal, tighten the screws to secure the TPS.
3. Install the throttle body onto the intake manifold with the gasket and the supplied M8 screws.
4. Connect the intake tube and throttle cable.
5. Connect the negative battery terminal.



IACV Spacer