

# DAVEFAB

BESPOKE | MOTORSPORT | FABRICATION

## **MX5/Miata Expansion Header Coolant Tank**

Mk3 / NC

D110-A001

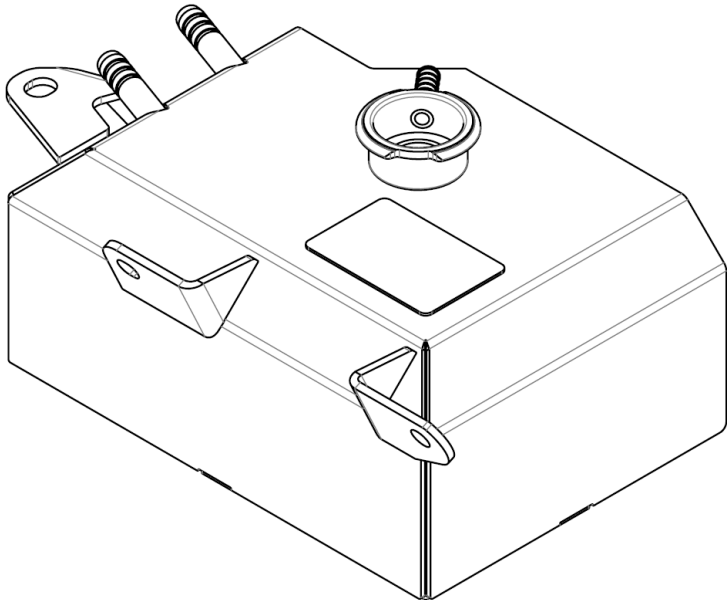

# DAVEFAB

BESPOKE | MOTORSPORT | FABRICATION

## **Carton Contents:**

1x D110-B001 - Expansion Tank

1x D110-B002 - Fitting Kit

- 1x Instruction Leaflet
- 1x Sticker

# DAVEFAB

BESPOKE | MOTORSPORT | FABRICATION

## Installation Instructions

### 1. Remove original plastic tank

- 1.1 Ensure engine has cooled down and coolant is not hot.
- 1.2 Remove and retain the original Mazda Cap from the factory tank, this will be reused.
- 1.3 Make a note of the coolant level in the original plastic tank, it may be necessary to remove some fluid during installation and you will need to top it up once finished.
- 1.4 Remove existing plastic expansion tank, it is secured with one bolt and two nuts. Retain the fasteners, they will be reused.
- 1.5 Disconnect the two upper hoses, making a note of which hose connects to each barb. Retain the hose clips, they will be reused.
- 1.6 Disconnect the lower hose. Retain the hose clip, it will be reused.

Note: some fluid will be in the hose, be prepared to catch this in a container

- 1.7 Empty the contents of the original tank into a container.
- 1.8 Remove the overflow hose as this will be reused.

### 2. Install the DaveFab tank

- 2.1 Connect the lower hose, securing with the original hose clip.
- 2.2 Position the DaveFab tank and secure with the original fasteners.
- 2.3 Reattach the two upper hoses to their barbs (front or rear) and secure with the original hose clips.
- 2.4 Refill the tank to the original level.
- 2.5 Fit the original Mazda Cap (FL22 - 108 kPa / 16 psi)
- 2.6 Ensure there is no air in the system. If you are unsure please consult a qualified mechanic.

# DAVEFAB

BESPOKE | MOTORSPORT | FABRICATION

## IMPORTANT

Use only OEM Mazda Cap  
(FL22 108kPa / 16 psi)

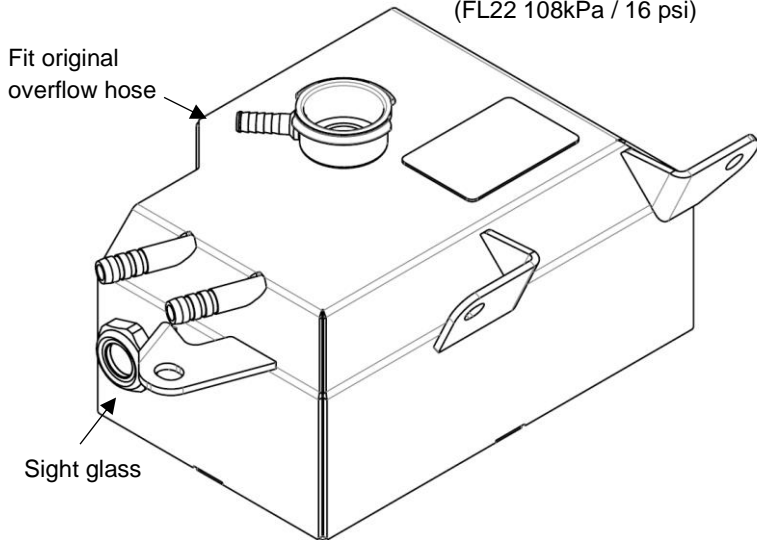

## IMPORTANT

This product is not compatible with Stant or other aftermarket radiator caps. For best performance we always recommend using the OEM Mazda Cap.

If you have any questions please let us know: [info@davefab.com](mailto:info@davefab.com)  
Thanks for supporting DaveFab!