

# DAVEFAB

BESPOKE | MOTORSPORT | FABRICATION

## MX5/Miata Oil Catch Can

Mk3 NC

D137-A001

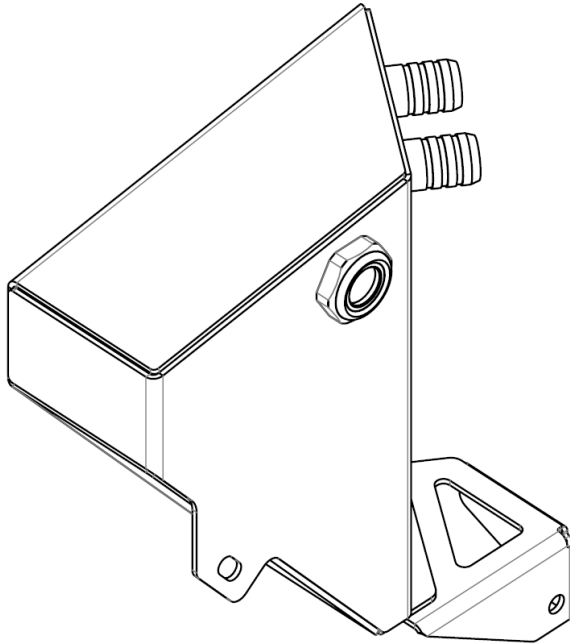

# DAVEFAB

BESPOKE | MOTORSPORT | FABRICATION

## **Carton Contents:**

1x D137-B001 - Catch Can

1x D137-B002 - Mounting Bracket

1x D137-B003 - Fitting Kit

- 1x Instruction Leaflet
- 1x Sticker
- 1x Cable Tie
- 4x WD027W2 Hose Clamp
- 2x 530118 Bolt M6x20
- 2x 530125 Spacer
- 2x 530132 Nylock Nut
- 2x 530008 Grommet

1x D137-B004 - 16mm Hose

# DAVEFAB

BESPOKE | MOTORSPORT | FABRICATION

## Installation Instructions

### Fit the mounting bracket

The Mounting bracket is secured to the existing lower hole in the strut tower.

1. Use the black spacer between the sheet metal and the bracket – this spaces the catch can away from the strut tower.
2. Secure with the nut.

### Fit the Catch Can

The catch can has two locating tabs that fit into the mounting bracket.

3. Carefully locate the mounting tabs and ensure they are seated fully
4. Use the second nut and bolt to secure the upper tab on the catch can to the strut tower.

Note: Locate the spacer between the catch can the sheet metal.

### Fit the hoses

5. Unclip the factory hose – carefully remove the green clip mechanism
6. Fit the short hose between the catch can port closest to the windscreen and the PCV valve on the valve cover (if necessary trim it for a perfect fit)
7. Fit the long hose between the other port and air intake. (if necessary trim it for a perfect fit). Secure with the hose clamps supplied.

# DAVEFAB

BESPOKE | MOTORSPORT | FABRICATION

8. Use the cable tie supplied to ensure that the long hose does not interfere with the moving belts on the engine. Secure with the hose clamps supplied

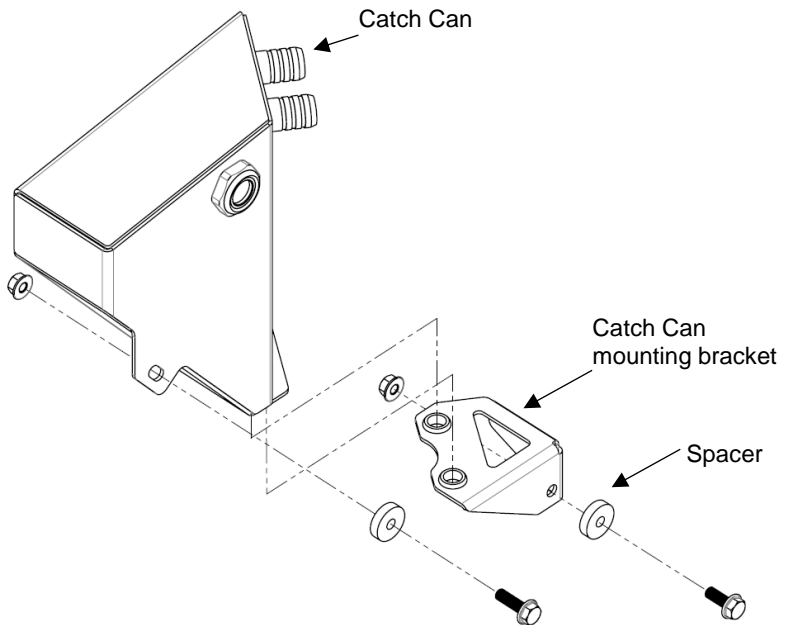

If you have any questions please let us know: [info@davefab.com](mailto:info@davefab.com)  
Thanks for shopping with DaveFab!