

General Instructions for Installing the BLP-1 Unit



The **BLP-1 Brake Light Pulser System** is a state of the art electronic module that, when installed properly, will provide you with years of trouble-free service.

The BLP-1 is designed to control the center high mount brake light (third brake light) of your car, and can be installed into almost any year or model of any car, minivan or truck. The function of the module is to gently pulse the center high mount brake lamp when you apply your brakes.

For color pictures, last minute updates, and some car specific information, visit <http://www.webelectricproducts.com/products.htm> and follow the Online Instructions link.

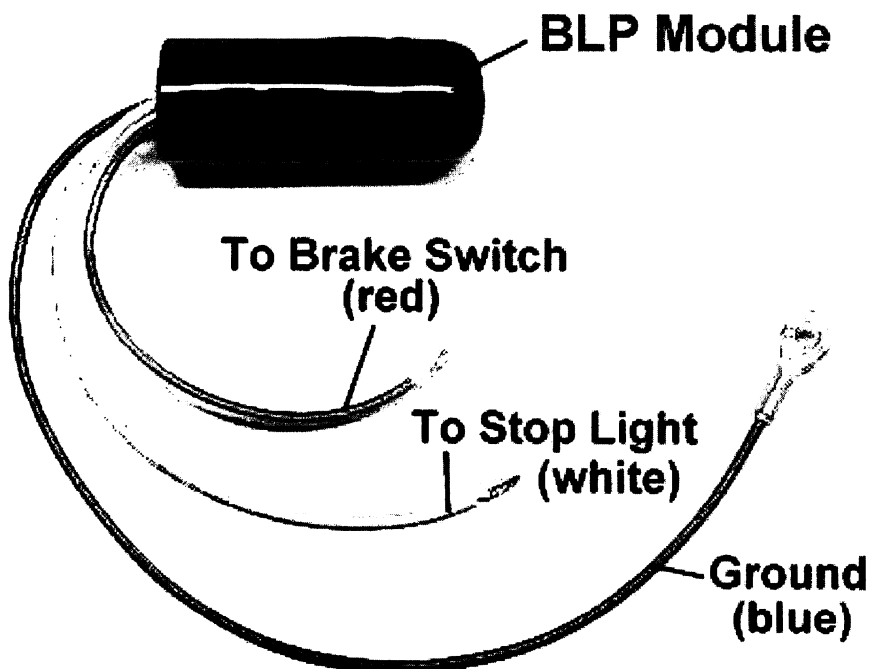

Making Connections

The kit comes complete with all the necessary wiring and connections to install into your car. One or more of the following connectors may be included in your kit. If you have never used quick connectors or wire nuts, read the section on these devices to familiarize yourself with how they work, and how to install them. If you've worked with them before, skip to the section that describes how to install the unit in your car.

A Quick-Splice Connector

Slide the existing harness wire into the Quick-Splice Connector from the side.



Insert the module wire into the end of the Quick-Splice Connector. Note that the insulation is not stripped.



Using a pair of pliers, carefully squeeze the metal tang until it is flush with the top of the connector. Make sure the tab is flush with the body of the connector, or it may not make a good connection.



A Wire Nut Connection

Strip 1/2" of insulation from both wires. Twist the wires together.

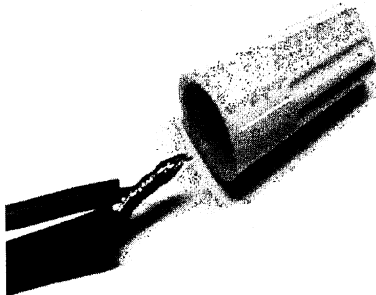

Screw the wire nut on to the wires until it's snug.

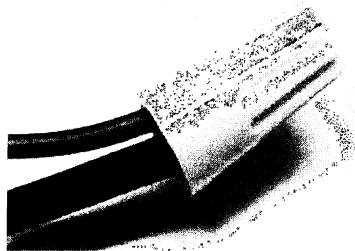

Fold the top over the connector and squeeze it closed to insulate the tang.

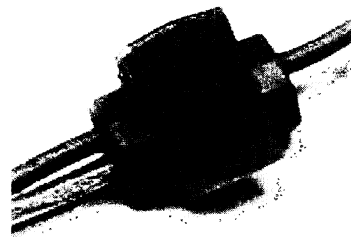

INSTALLATION INSTRUCTIONS

There are two types of center high mount brake lamps in cars; 1-wire and 2-wire. After determining the type of wiring your car has, follow the instructions below.

1-Wire Installation

- 1) In this system, there is one wire that goes to the brake lamp. The other wire, which is ground, completes the circuit through the frame of the car.

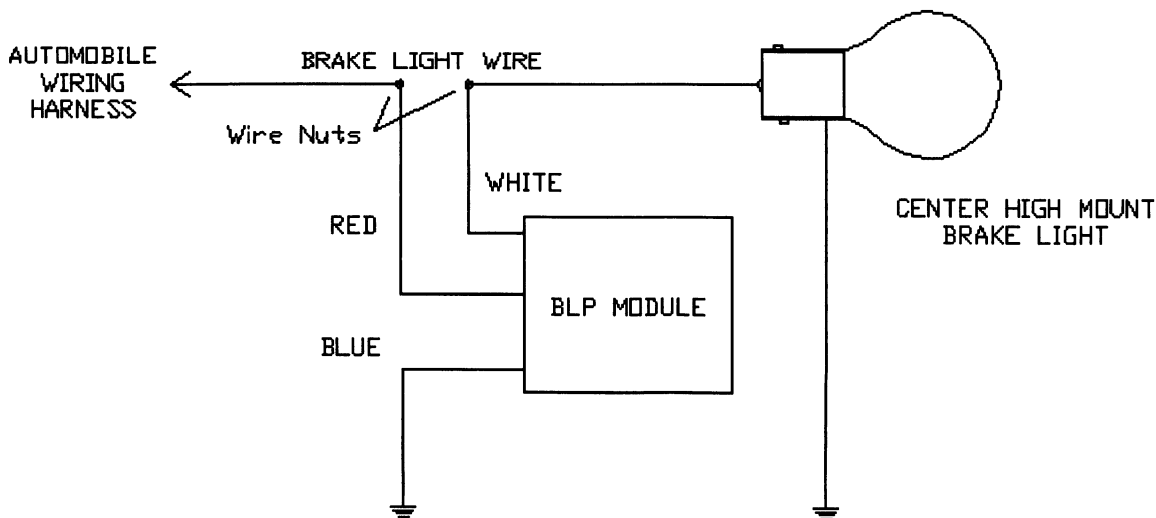

Make the following connections to the module as shown in the diagram:

- 2) Cut the single wire that goes to the brake lamp, and strip about 1/2" of insulation off both wires.
- 3) Using a wire nut, connect the RED wire from the module to the wire that comes from the BRAKE PEDAL.
- 4) Using a wire nut, connect the WHITE wire from the module to the wire that goes to the CENTER HIGH MOUNT BRAKE LIGHT.
- 5) Connect the BLUE wire from the module to a suitable chassis ground. This can be a screw on the frame of the car, or on the body of the brake light housing. Where you make this connection is important. It must be a connection to a metal part of the car that is already grounded.
- 6) Proceed to the section on Testing.

2-Wire Installation

- 1) In this system, there are two wires that go to the brake lamp. One wire is the brake light power, and the other wire is ground. You must identify these wires correctly in order for your module to function properly.

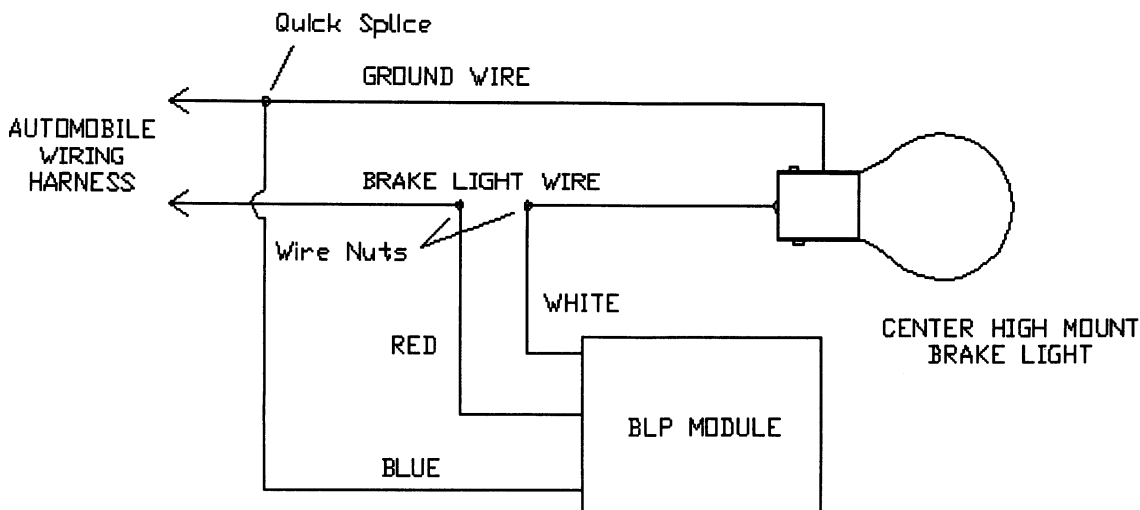

Make the following connections to the module as shown in the diagram:

- 2) Cut the BRAKE LIGHT wire that goes to the brake lamp, and strip about 1/2" of insulation off both wires.
- 3) Using a wire nut, connect the RED wire from the module to the wire that comes from the BRAKE PEDAL.
- 4) Using a wire nut, connect the WHITE wire from the module to the wire that goes to the CENTER HIGH MOUNT BRAKE LIGHT.
- 5) With a wire cutters, remove the ring terminal from the BLUE module wire.
- 6) Using a quick splice connector, connect the BLUE wire from the module to the GROUND wire of the brake lamp.
- 7) Proceed to the section on Testing.

TESTING

With the engine off, stand behind the car and look at the center high mount brake lamp. Ask someone to press the brake pedal. The lamp should pulse on and off for about 1 second, then it should stay on. Ask the person to release the brake pedal, and the lamp should turn off. If you press the pedal again within 15 seconds, the lamp will not pulse, it will just come on like normal. Release the pedal and wait 15 seconds or more. Press the pedal again, and the lamp will pulse then turn on. If something isn't working, double check your wiring for errors.

Use the supplied tie wraps to bundle up the wires and to fasten the module to the wiring harness. **DO NOT** over tighten the tie wraps that hold the module to the harness. If you damage the body of the module, the unit may not function properly or may allow moisture into the system.

If you are installing the module where it can get wet (like the back of a Corvette, or a motorcycle) make sure you mount it so that it is **oriented with the top up, and the wires pointing down**. If water condenses on the wires, it might seep into the module and destroy it.